

Lantech

IEC-0101FT

1 10/100TX to 100M-FX Slim Type Converter

User Manual



FCC Warning

This Equipment has been tested and found to comply with the limits for a Class A digital device, pursuant to Part 15 of the FCC rules. These limits are designed to provide reasonable protection against harmful interference in a residential installation. This equipment generates, uses, and can radiate radio frequency energy. It may cause harmful interference to radio communications if the equipment is not installed and used in accordance with the instructions. However, there is no guarantee that interference will not occur in a particular installation. If this equipment does cause harmful interference to radio or television reception, which can be determined by turning the equipment off and on, the user is encouraged to try to correct the interference by one or more of the following measures:

- Reorient or relocate the receiving antenna.
- Increase the separation between the equipment and receiver.
- Connect the equipment into an outlet on a circuit different from that to which the receiver is connected.
- Consult the dealer or an experienced radio/TV technician for help.

CE Mark Warning

This is a class A product. In a domestic environment this product may cause radio interference in which case the user may be required to take adequate measures.

Content

FCC Warning	i
CE Mark Warning.....	i
Overview	1
Introduction	1
Features	3
Packing List.....	4
Safety Precaution.....	4
Hardware Description.....	5
Front Panel.....	5
Top View	6
Wiring the Power Inputs	6
Wiring the Fault Alarm Contact	7
LED Indicators.....	7
DIP-Switch	8
Ports	9
Cabling	11
Mounting Installation	12

DIN-Rail Mounting.....	12
Wall Mount Plate Mounting	14
Network Connection.....	15
Installation Steps.....	15
Troubles shooting.....	17
Technical Specification	18

Overview

Introduction

The Industrial 10/100Base TX to 100BaseFX Media Converter is a cost-effective solution for the converting between 10/100Base-TX and 100Base-FX cabling, it allows you to extend the cabling distance of your 100Base-FX network up to 2 kilometers for multi-mode fiber or 30 kilometers for single-mode fiber. The Fast Fiber Converter module gives you the option to choose from the most popular fiber cabling connectors: SC multi-mode and single-mode connector.

Fast Fiber Converters Module

The Industrial 10/100Base TX to 100BaseFX Media Converter provides you with one Fiber connector for your fiber optic cable and one Ethernet RJ-45 port (Auto MDI/MDIX) for your 100Base-TX copper cable connection. There are four DIP-switches to set the operation mode for UTP, Fiber ports and link loss forwarding function.

Dual Power Input

To reduce the risk of power failure, the Industrial 10/100Base TX to 100BaseFX Media Converter provides +12 ~ 48 V_{DC} dual power inputs. If there is power failure, Industrial 10/100Base TX to 100BaseFX Media Converter will automatically switch to the secondary power input.

Flexible Mounting

Industrial 10/100Base TX to 100BaseFX Media Converter is extremely compact and can be mounted on a DIN-rail or a panel, so it is suitable for any space-constrained environment.

Advanced Protection

The power line of Industrial 10/100Base TX to 100BaseFX Media Converter supports up to 3,000 V_{DC} EFT protection, which secure equipment against unregulated voltage and make systems safer and more reliable. Meanwhile, 6,000 V_{DC} ESD protections for Ethernet ports

make Industrial 10/100Base TX to 100BaseFX Media Converter more suitable for harsh environments.

Wide Operating Temperature

The operating temperature of the Industrial 10/100Base TX to 100BaseFX Media Converter is between -40 ~ 75°C (wide operating temperature model) or -10 ~ 60°C (standard model). With such a wide range, you can use the Industrial 10/100Base TX to 100BaseFX Media Converter in some of the harshest industrial environments that exist.

Easy Troubleshooting

LED indicators make troubleshooting quick and easy. The 10/100 Base-TX port has 2 LEDs that display the link status, transmission speed and collision status. Also the three power indicators P1, P2 and Fault help you diagnose immediately.

Features

- Provides 1 x 10/100Mbps Ethernet ports with RJ-45 connector
- Provides 1 x SC (multi-mode & single-mode) fiber connector
- Supports full/half duplex flow control
- Supports MDI/MDI-X auto-crossover
- Supports surge (EFT) protection 3,000 V_{DC} for power line
- Supports 6,000 V_{DC} Ethernet ESD protection
- Supports auto-negotiation
- Supports store & forward transmission
- Supports redundant +12 ~ 48 V_{DC} power input
- Provides flexible mounting: DIN-rail, Wall Mounting
- Supports operating temperatures from -40 ~ 75°C (wide operating temperature model) or -10 ~ 60°C (standard model)

Packing List

- 1 x Industrial 10/100BaseTX to 100BaseFX Media Converter
- 1 x User manual
- 2 x Wall Mounting Bracket and Screws
- 1 x DIN-rail Mounting Bracket and Screws

Safety Precaution

Attention IF DC voltage is supplied by an external circuit, please use a protection device on the power supply input.

Hardware Description

In this chapter, you will be given an overview of the Industrial 10/100Base TX to 100BaseFX Media Converter hardware installation procedures.

Front Panel

The Front Panel of the Industrial 10/100Base TX to 100BaseFX Media Converter is shown as follows.

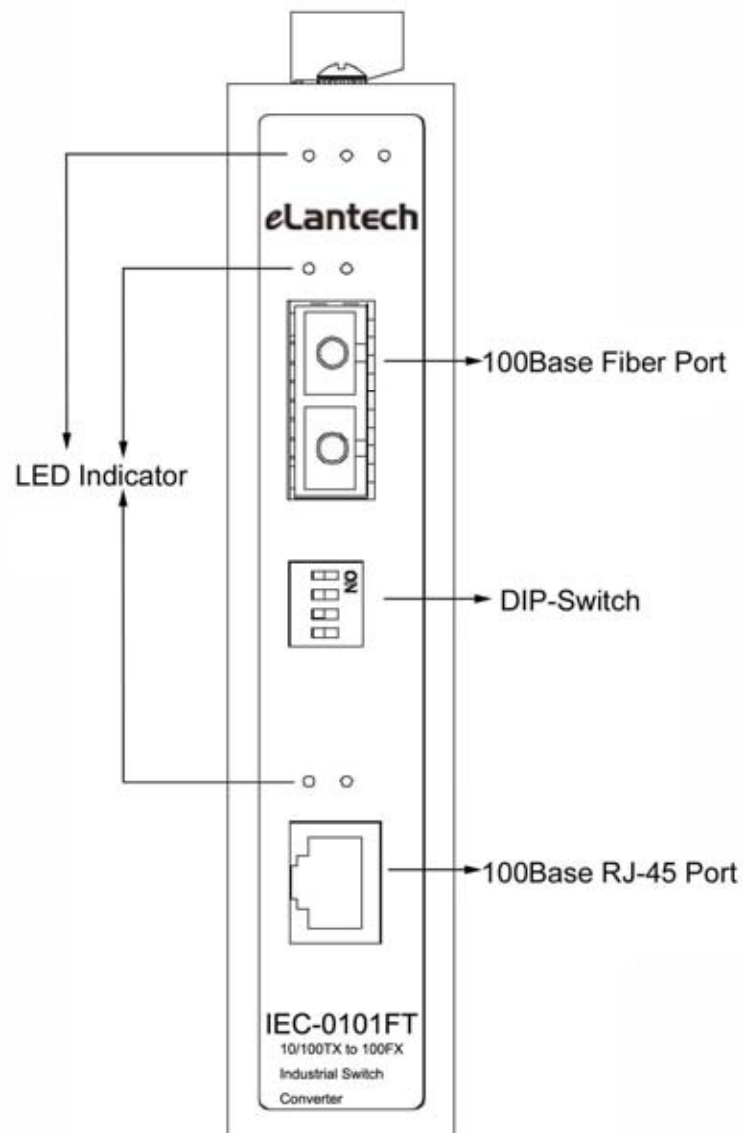

Front Panel of the Industrial 10/100TX to 100FX Media Converter

Top View

The top panel of the Industrial 10/100Base TX to 100BaseFX Media Converter is equipped one terminal block connector of two DC power inputs.

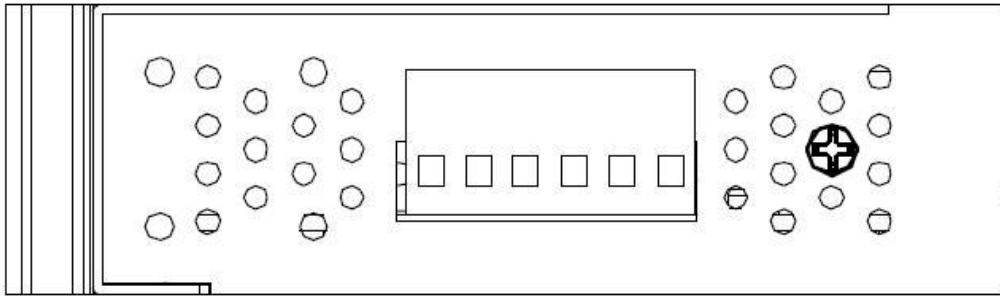

Top Panel of the Industrial 10/100Base TX to 100BaseFX Media Converter

Wiring the Power Inputs

Please follow the steps below to insert the power wire.

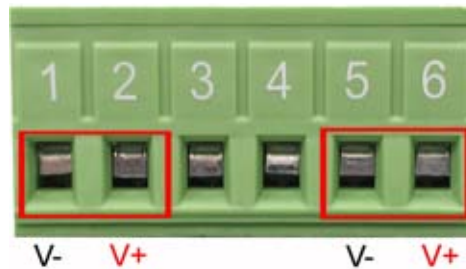

Insert the positive and negative wires into the V+ and V- contacts on the terminal block connector.



Tighten the wire-clamp screws for preventing the wires from loosing.

Wiring the Fault Alarm Contact

The fault alarm contact is in the middle of terminal block connector as the picture shows below. Inserting the wires, it will detect the fault status including power failure/port link failure and form an open circuit.



Insert the wires into the fault alarm contact.

Note *The wire gauge for the terminal block should be in the range between 12~ 24 AWG.*

LED Indicators

There are few LEDs, which display the power status and network status, located on the front panel of the Industrial 10/100Base TX to 100BaseFX Media Converter, each of them has its own specific meaning as below table.

LED	Color	Description	
P1	Green	On	Power input 1 is active
		Off	Power input 1 is inactive
P2	Green	On	Power input 2 is active
		Off	Power input 2 is inactive
Fault	Red	On	Power input 1 or 2 has failed
		Off	Power input 1 and 2 are both functional, or no power inputs
FDX/COL (fiber port)	Yellow	On	Full-duplex mode
		Flashing	Packet collision occurred

		Off	Half-duplex mode
LNK/ACT (fiber port)	Green	On	Connected to network
		Flashing	Networking is active
		Off	Not connected to network
100M (RJ-45)	Yellow	On	Link to 100Mbps network
		Off	Link to 10Mbps network
LNK/ACT (RJ-45)	Green	On	Connected to network
		Flashing	Networking is active
		Off	Not connected to network

DIP-Switch

The DIP-Switch is used to configure operation mode for **LFP (Link Fault Pass-Through)** and operation mode for UTP/Fiber port. The default value of DIP-switch is **OFF**.

S/W No	Status	Description
1	ON	Enables Port/Power Alarm
	OFF	Disable Port/Power Alarm
2	ON	Enables LFP
	OFF	Disables LFP
3	ON	100Base-FX Half-mode
	OFF	100Base-FX Full-mode
4	ON	Media mode (100TX to 100FX)
	OFF	Switching mode

Link Fault Pass-Through (DIP-Switch 2): When LFP enabled, it allows UTP link failures to be reported to the fiber side and also allows Fiber link failures to be reported to the UTP side. Therefore, a link fault pass-through feature is provided in both UTP and Fiber side.

Media mode (DIP-Switch 4): When media mode is enabled (ON), it operates with the minimum latency. The transmission flow does not wait until entire frame is ready, but instead it forwards the received data immediately after the data being received. And TP port should be forced at 100M in this application. When DIP-Switch is in switching mode (OFF), the converter function is the same as a Switch Hub.

Note Please don't change the DIP-switch setting when UTP or fiber port is transmitting or receiving data. It may cause some data error. Besides, if you change the DIP-switch setting, please power off the converter and power on again to make the setting effective.

Ports

RJ-45 ports (Auto MDI/MDIX): The RJ-45 ports are auto-sensing for 10Base-T or 100Base-TX devices connections. Auto MDI/MDIX means that you can connect to another switch or workstation without changing straight through or crossover cabling. See figures as below for straight through and crossover cable schematic.

■ RJ-45 Pin Assignments

Pin Number	Assignment
1	Tx+
2	Tx-
3	Rx+
6	Rx-

Note “+” and “-” signs represent the polarity of the wires that make up each wire pair.

All ports on this unit support automatic MDI/MDI-X operation, you can use straight-through cables (See Figure below) for all network connections to PCs or servers, or to other switches or hubs. In straight-through cable, pins 1, 2, 3, and 6, at one end of the cable, are connected straight through to pins 1, 2, 3 and 6 at the other end of the cable. The table below shows the 10BASE-T/ 100BASE-TX MDI and MDI-X port pin outs.

Pin MDI-X	Signal Name	MDI Signal Name
1	Receive Data plus (RD+)	Transmit Data plus (TD+)

2	Receive Data minus (RD-)	Transmit Data minus (TD-)
3	Transmit Data plus (TD+)	Receive Data plus (RD+)
6	Transmit Data minus (TD-)	Receive Data minus (RD-)

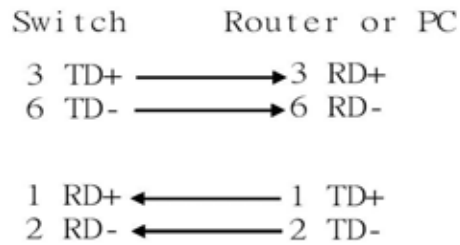

Straight Through Cable Schematic

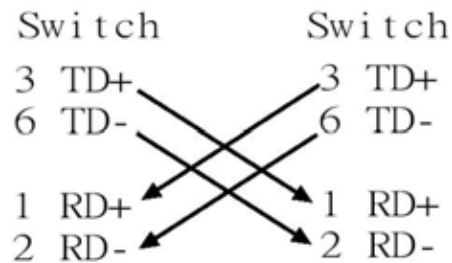

Cross Over Cable Schematic

■ Fiber Port

The fiber port of SC type connector can work in multi mode (2Km) or single mode (30Km).

When you connect the fiber port to another one, please follow the figure below to connect accordingly. Wrong connection will cause the port cannot work normally.

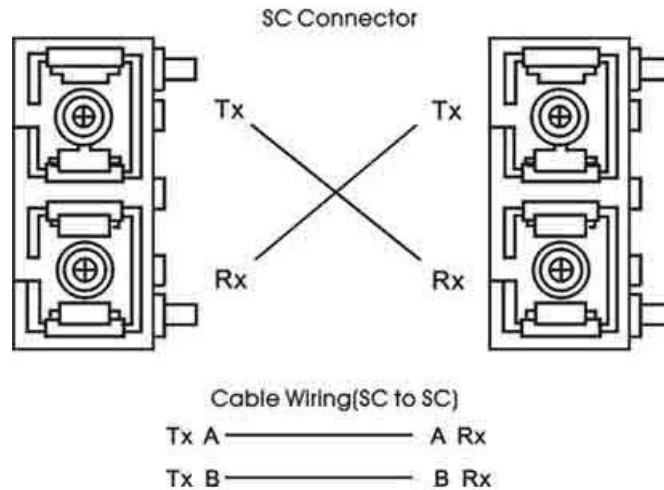

ATTENTION



This is a Class 1 Laser/LED product. Don't stare into the Laser/LED Beam.

Cabling

- Twisted-pair segment can be connected with unshielded twisted pair (UTP) or shielded twisted pair (STP) cable. The cable must comply with the IEEE 802.3u 100Base TX standard for Category 5. The cable between the converter and the link partner (converter, switch, hub, workstation, etc.) must be less than 100 meters (328 ft.) long.
- Fiber segment using **single-mode** connector type must use 9/125µm single-mode fiber cable. User can connect two devices in the distance up to **30 Kilometers**.
- Fiber segment using **multi-mode** connector type must use 50 or 62.5/125 µm multi-mode fiber cable. User can connect two devices up to **2Km** distances.

Mounting Installation

DIN-Rail Mounting

The DIN-Rail is screwed on the unit when out of factory. If the DIN-Rail is not screwed on the unit, please see the pictures and follow the steps below to screw the DIN-Rail on the unit.

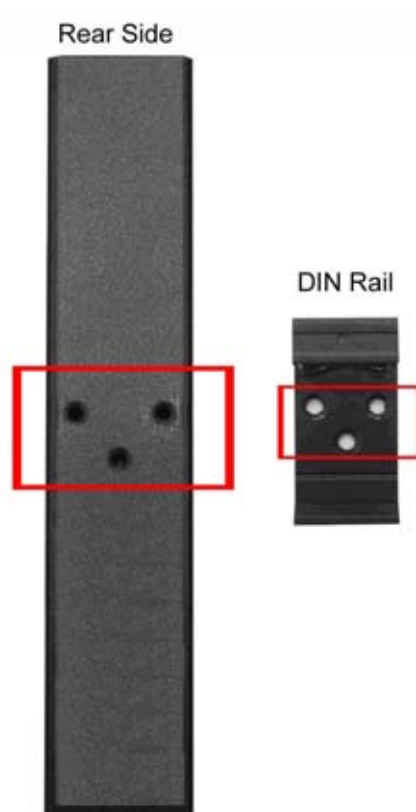

1. Use the screws to screw the DIN-Rail on the rear side of the unit.
2. To remove the DIN-Rail, reverse the step 1.

3. After the DIN-Rail is screwed on the rear side of the unit, insert the top of DIN-Rail into the track.



4. Then, lightly push the DIN-Rail into the track.

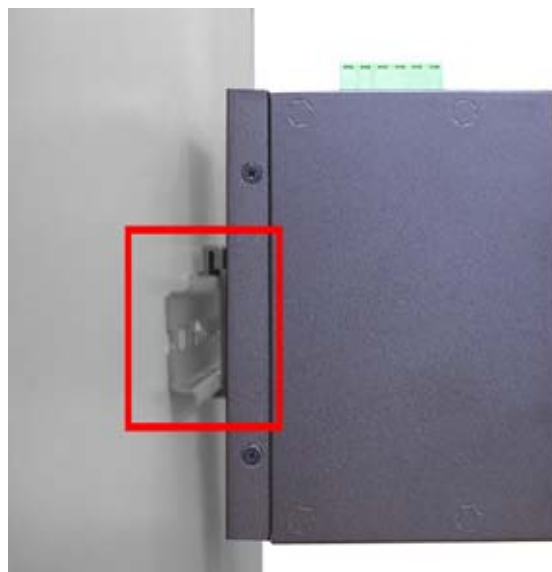

5. Check if the DIN-Rail is tightened on the track or not.
6. To remove the unit from the track, reverse steps above.

Wall Mount Plate Mounting

Follow the steps below to mount the unit with wall mount plate.

1. Remove the DIN-Rail from the unit; loose the screws to remove the DIN-Rail.
2. Place the wall mount plate on the top & bottom side of the unit.
3. Use the screws to screw the wall mount plate on the unit.
4. Use the hook holes at the corners of the wall mount plate to hang the unit on the wall.
5. To remove the wall mount plate, reverse steps above.

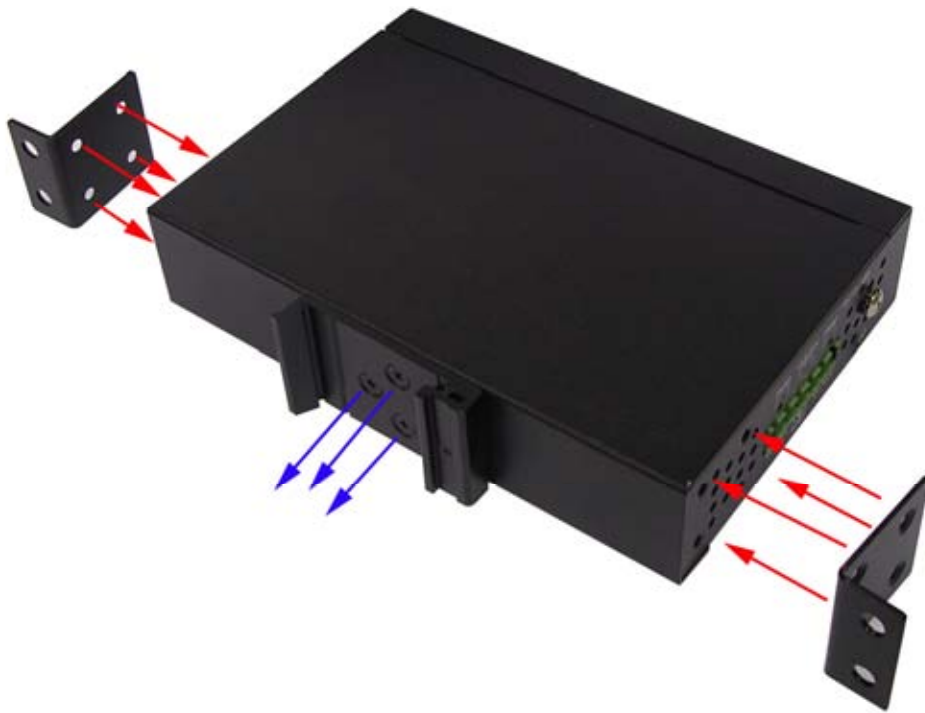

Network Connection

In this paragraph, we will describe how to install the Industrial 10/100Base TX to 100BaseFX Media Converter.

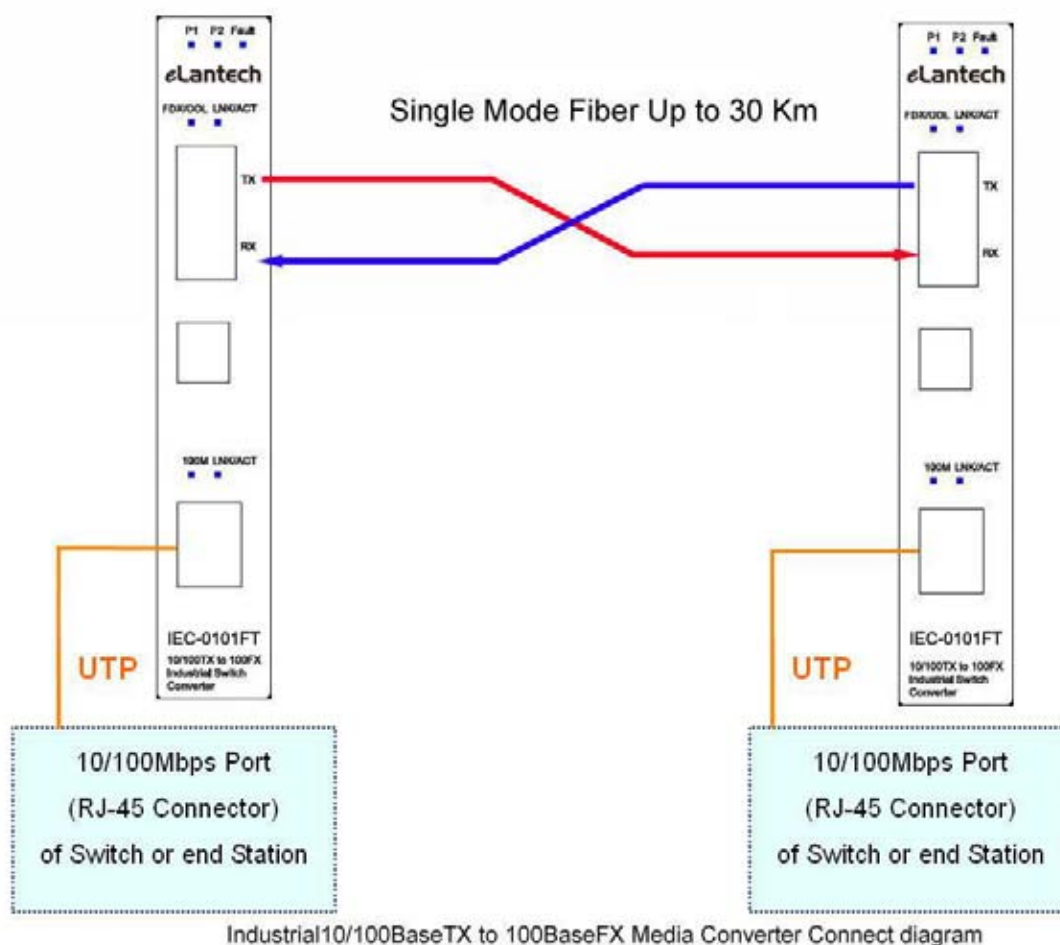

Installation Steps

1. Unpack the unit packing.
2. Check the DIN-Rail is screwed on the unit. If the DIN-Rail is not screwed on the unit. Please refer to **DIN-Rail Mounting** section for DIN-Rail installation. If you want to wall mount the unit, then please refer to **Wall Mount Plate Mounting** section for wall mount plate installation.

3. To hang the unit on the DIN-Rail track or wall, please refer to the **Mounting Installation** section.
4. Power on the Unit. How to wire the power; please refer to the **Wiring the Power Inputs** section. The power LED on the unit will light up. Please refer to the **LED Indicators** section for meaning of LED lights.
5. Prepare the twisted-pair, straight through Category 5 cable for Ethernet connection.
6. Insert one side of Category 5 cables into the Ethernet port (RJ-45 port) and another side of category 5 cables to the network devices' Ethernet port (RJ-45 port), ex: switch, PC, or Server. The UTP port (RJ-45) LED on the unit will light up when the cable connected with the network device. Please refer to the **LED Indicators** section for LED light meaning.
7. Connect one end of the fiber cable to the SC single-mode connector on this converter and the other end of the fiber cable to the SC single-mode connector on the other 100 Base-FX device.

Note *Be sure the connected network devices support MDI/MDI-X. If it does not support, then use the crossover category 5 cable.*

8. When all connections are all set and LED lights all show in normal, the installation is complete.

Troubleshooting

- Verify that you are using the right power cord/adaptor (DC 12-48V), please don't use the power adaptor with DC output bigger than 48V, or it will burn this converter down.
- Select the proper UTP/STP cable to construct your network. Please check that you are using the right cable. Use unshielded twisted-pair (UTP) or shield twisted-pair (STP) cable for RJ-45 connections: 100 Ω Category 3, 4 or 5 cables for 10Mbps connections or 100 Ω Category 5 cable for 100Mbps connections. Also be sure that the length of any twisted-pair connection does not exceed 100 meters (328 feet).
- **Diagnosing LED Indicators:** the unit can be easily monitored through panel indicators to assist in identifying problems, which describes common problems you may encounter and where you can find possible solutions.
- IF the power indicator does not light on when the power cord is plugged in, you may have a problem with power cord. Then check for loose power connections, power losses or surges at power outlet. IF you still cannot resolve the problem, contact your local dealer for assistance.
- If the LED indicators are normal and the connected cables are correct and the packets still cannot transmit. Please check your system's Ethernet devices' configuration or status.

Technical Specification

The technical specifications of the unit are listed as follows.

Communications

Compatibility	IEEE 802.3, 802.3u, 802.3x
LAN	10/100Base-TX
Transmission Distance	Multi-Mode Fiber 2km Single-Mode Fiber 30km
Transmission Speed	Up to 100 Mbps

Interface

Connectors	Fiber : SC (multi-mode & single-mode) 1 x RJ-45 6-pin removable screw terminal (power & relay)
LED Indicators	Unit: P1, P2, Fault Ethernet port: 10/100M, Link/Active Fiber: HDX/FDX, LNK/ACT

Power

Power Consumption	2.74 W
Power Input	2 x Unregulated +12 ~ 48 V _{DC}
Fault Output	1 Relay Output (The power supply should meet the “document listed by UL” and its output must comply with L.P.S)

Mechanism

Dimensions (WxHxD)	30 x 95 x 140 mm
Enclosure	IP30, Metal shell with solid mounting kits
Mounting	DIN35 rail, Wall

Protection

ESD (Ethernet)	6,000 V _{DC}
Surge (EFT for power)	3,000 V _{DC}
Power Reverse	Yes

Environment

Operating Temperature	-40 ~ 75°C (wide operating temperature model) -10 ~ 60°C (standard model)
Operating Humidity	5% ~ 95% (non-condensing)
Storage Temperature	-40 ~ 85°C

Certifications

Safety	UL, cUL, CE/EN60950-1
EMI	FCC Class A, CE EN61000-4-2 (ESD), CE EN61000-4-3 (RS), CE EN-61000-4-4 (EFT), CE EN61000-4-5 (Surge), CE EN61000-4-6 (CS), CE EN61000-4-8, CE EN61000-4-11,

Free Fall
Shock
Vibration

CE EN61000-4-12,
CE EN61000-6-2,
CE EN61000-6-4
IEC60068-2-32
IEC60068-2-27
IEC60068-2-6