

Lantech

LGS-1104

4 10/100/1000T

+ 1 MINI GBIC Web Managed Switch

User Manual



Rev.1.20
24-Dec-2007

FCC Warning

This Equipment has been tested and found to comply with the limits for a Class A digital device, pursuant to Part 15 of the FCC rules. These limits are designed to provide reasonable protection against harmful interference in a residential installation. This equipment generates, uses, and can radiate radio frequency energy. It may cause harmful interference to radio communications if the equipment is not installed and used in accordance with the instructions. However, there is no guarantee that interference will not occur in a particular installation. If this equipment does cause harmful interference to radio or television reception, which can be determined by turning the equipment off and on, the user is encouraged to try to correct the interference by one or more of the following measures:

- Reorient or relocate the receiving antenna.
- Increase the separation between the equipment and receiver.
- Connect the equipment into an outlet on a circuit different from that to which the receiver is connected.
- Consult the dealer or an experienced radio/TV technician for help.

CE Mark Warning

This is a Class-A product. In a domestic environment this product may cause radio interference in which case the user may be required to take adequate measures.

Content

FCC Warning	2
CE Mark Warning.....	2
INTRODUCTION	1
Features	1
Software Feature.....	2
Package Contents.....	3
HARDWARE DESCRIPTION.....	4
Physical dimension	4
Front Panel.....	4
Rear Panel	5
LED Indicators.....	5
Desktop Installation.....	7
Attaching Rubber Feet	7
Power On	7
NETWORK APPLICATION.....	8
Small Workgroup.....	8
Segment Bridge	8
WEB-BASED MANAGEMENT	10
About Web-based Management.....	10
System Login	10
System Configuration	11
Port Configuration	13
Statistics-1 (Overview)	14
Statistics-2 (Detailed)	15
VLAN Setting.....	15
VLAN Port Setting.....	16
Port Trunk	17
LACP Setting.....	18

LACP Status	19
Spanning Tree	20
RSTP System Configuration.....	20
RSTP Port Configuration	22
Spanning Tree Status	22
802.1X Configuration	23
Parameters Configuration.....	24
QoS Setting	25
System Restart	28
Factory Default	28
Firmware Upload	28
Configuration Upload/Download	29
TROUBLESHOOTING	31
Incorrect connections.....	31
Faulty or loose cables	31
Non-standard cables	31
Improper Network Topologies	32
Diagnosing LED Indicators	32
TECHNICAL SPECIFICATION	33
APPENDIX	36
10 /100BASE-TX Pin outs	36
10/100Base-TX Cable Schematic.....	36
10/100/1000Base-TX Pin outs.....	37
10/100/1000Base-TX Cable Schematic.....	38

Introduction

The 4 10/100/1000T + 1 Mini-GBIC Web Managed Switch is a multi-port Switch that can be used to build high-performance switched workgroup networks. The Switch is targeted at workgroup or department.

The 4 10/100/1000T + 1 Mini-GBIC Web Managed Switch features a “store-and-forward “ switching scheme that offers low latency for high-speed networking and allows the switch to auto-learn and store source address in a 8K-entry MAC address table.

The 4 10/100/1000T + 1 Mini-GBIC Web Managed Switch has 4 auto-sensing 10/100/1000 Base-TX RJ-45 ports + 1 MINI GBIC slot that enables extended distance connection.

Features

- Conforms to IEEE 802.3, 802.3u, 802.3ab, 802.3x and 802.1x
- Store-and-Forward switching architecture
- Web Management
- Auto-MDIX on all ports
- 10Gbps back-plane
- N-Way Auto-Negotiation
- Supports Port Based VLAN
- Supports Class of Service
- Supports STP (Spanning Tree Protocol)
- Supports Port Trunk
- Back pressure with half duplex (10/100Mbps)
- Flow control with full duplex (10/100/1000Mbps)
- Web Firmware upgrade

- 8K MAC address table
- 112Kbytes memory buffer
- True non-blocking switching
- 8K Jumbo Frame supported

Software Feature

Management	Web Management
Firmware update	Web UI firmware update
System default	One default button for system default Default IP: 192.168.16.1 Gateway: 192.168.16.254 Subnet Mask: 255.255.255.0
Port Trunk	IEEE802.3ad port trunk with link aggregation control protocol (LACP) The trunk group up to 2 and maximum trunk port member up to 2 ports.
VLAN	Port Based VLAN VLAN ID up to 5 VLAN group up to 5
DHCP	DHCP client feature
Quality of Service	Port based Tag based IPv4 ToS
Class of Service	Per port supports 4 priority queues

Spanning Tree	IEEE802.1w rapid spanning tree and compatible with IEEE 802.1d
----------------------	--

Package Contents

Unpack the contents of the 4 10/100/1000T + 1 Mini-GBIC Web Managed Switch and verify them against the checklist below:

- 4 10/100/1000T + 1 Mini-GBIC Web Managed Switch
- DC Power Cord
- Four Rubber Pads
- User Manual



4 10/100/1000T + 1 Mini-GBIC Web Managed Switch



Four Rubber Pads

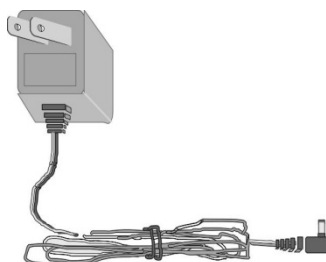

DC Power Adapter

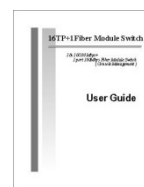

User Manual

Package Contents

Compare the contents of your 4 10/100/1000T + 1 Mini-GBIC Web Managed Switch package with the standard checklist above. If any item is missing or damaged, please contact your local dealer for exchanging.

Hardware Description

This section mainly describes the hardware of the 4 10/100/1000T + 1 Mini-GBIC Web Managed Switch, and gives a physical and functional overview on certain switch.

Physical dimension

The 4 10/100/1000T + 1 Mini-GBIC Web Managed Switch physical dimension is **165 x 100 x 32.5 mm** (W x D x H).

Front Panel

The Front Panel of the 4 10/100/1000T + 1 Mini-GBIC Web Managed Switch consists of LED Indicators and a reset button. Please refer to LED Indicator section for LED description.

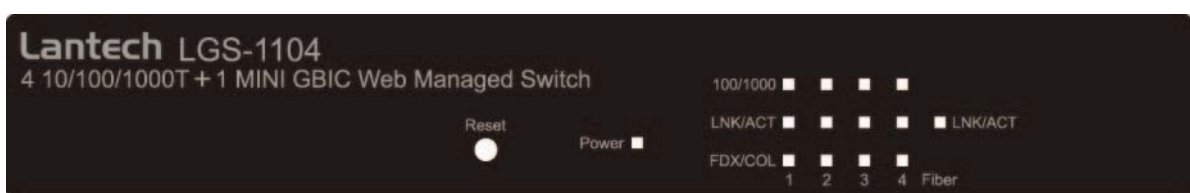

- **Reset button:** It provides an easy way for user to reset the configuration back to the default settings. Press the button more than 5 seconds, and then the switch will restart and set all configurations back to the default settings.

Rear Panel

The rear panel consists of the 4 10/100/1000Base-TX RJ-45 port, one Mini GBIC slot, and DC Power Jack as shown in the figure below. The switch will work with DC in the range of 12V/0.8A.



The Rear Panel of 4 10/100/1000T + 1 Mini-GBIC Web Managed Switch

- **RJ-45 Ports (Auto MDI/MDIX):** 4x 10/100/1000 N-way auto-sensing for 10Base-T, 100Base-TX or 1000Base-T connections.
In general, **MDI** means connecting to another Hub or Switch while **MDIX** means connecting to a workstation or PC. Therefore, **Auto MDI/MDIX** would allow connecting to another Switch or workstation without changing non-crossover or crossover cabling.
- **Mini GBIC slot:** The appropriate replaceable Mini-GBIC port is available with a variety of different transmitter and receiver types, allowing users to select the appropriate transceiver for each link to provide the required optical reach over the available optical fiber type. There is one LED indicator—LNK/ACT—for Mini-GBIC port on the front panel.

LED Indicators

The LED Indicators display the real-time information of systematic operation status. Please see definition of the LED indicators as follows.

LED	Status	Color	Description
Power	On	Green	Power On
	Off	--	No Power inputs or Power cord disconnected
100/1000	On	Green	The port is operating at the speed of 1000Mbps.
	On	Yellow	The port is operation at the speed of 100Mbps.
	Off	--	In 10Mbps mode or no device attached
LNK /ACT	On	Green	The port is well connected with the device.
	Blinks	Green	The port is in processing of receiving or transmitting data.
	Off	--	No device attached.
FDX /COL	On	Yellow	The port is operating in Full-duplex mode.
	Blinks	Yellow	Collision of Packets occurs in the port.
	Off	--	Half-duplex mode or no device attached.
LNK /ACT (MINI GBIC)	On	Green	The port is well connected with the device.
	Blinks	Green	The port is in processing of receiving or transmitting data.
	Off	--	No data transmitted or no device connected

The Definition of LED Indicators

Desktop Installation

Set the switch on a sufficiently large flat space with a power outlet nearby. The surface where you put the switch should be clean, smooth, level and sturdy. Make sure there is enough clearance around the switch to allow attachment of cables, power cord and allow air circulation.

Attaching Rubber Feet

- A. Make sure mounting surface on the bottom of the switch is grease and dust free.
- B. Remove adhesive backing from your Rubber Pads.
- C. Apply the Rubber Feet to each corner on the bottom of the switch. These footpads can prevent the switch from shock/vibration.

Power On

Connect the power adaptor to the power jack on the rear panel of the switch. The other side of power adaptor is connected to the power outlet. The external power supply in the switch works with DC power in 12V/0.8A. Please check with the power indicator on the front panel to see if power is properly supplied.

Network Application

This section provides user a few samples of network topology in witch the switch is used. In general, the 4 10/100/1000T + 1 Mini-GBIC Web Managed Switch is designed as a segment switch. That is, with its address table (8000 MAC address) and high performance, it is ideal for interconnecting networking segments.

PC, workstations, and servers can communicate each other by directly connecting with 4 10/100/1000T + 1 Mini-GBIC Web Managed Switch. The switch automatically learns nodes address, which are subsequently used to filter and forward all traffic based on the destination address.

By using Uplink port, the switch can connect with another switch or hub to interconnect other small-switched workgroups to form a larger switched network. Meanwhile, you can also use fiber ports to connect switches. The distance between two switches via fiber cable depends on the type of fiber transceiver.

Small Workgroup

The 4 10/100/1000T + 1 Mini-GBIC Web Managed Switch can be used as a standalone switch to which personal computers, server, printer server, are directly connected to form small workgroup.

Segment Bridge

For enterprise networks where large data broadcasts are constantly processed, this switch is an ideal solution for department users to connect to the corporate backbone.

Two 4 10/100/1000T + 1 Mini-GBIC Web Managed Switches with PCs, print server, and local server attached, are both connected to the core switch. All the devices in this network can communicate with each other through the 4 10/100/1000T + 1 Mini-GBIC Web Managed Switch. Connecting servers to the 4 10/100/1000T + 1 Mini-GBIC Web Managed Switch allows users accessing the data on server. By using fiber ports to connect switches, the distance between two switches depends on the type of fiber transceiver.

Web-Based Management

This section introduces the function of the 4 10/100/1000T + 1 Mini-GBIC Web Managed Switch configuration.

About Web-based Management

On the CPU board of the switch there is an embedded HTML web site residing in flash memory, which offers advanced management features and allow users to manage the switch from anywhere on the network through a standard browser such as Microsoft Internet Explorer.

The Web-Based Management supports Internet Explorer 6.0. And, it is applied with Java Applets for reducing network bandwidth consumption, enhance access speed and present an easy viewing screen.

System Login

The default value list as below:

- IP Address: **192.168.16.1**
- Subnet Mask: **255.255.255.0**
- Default Gateway: **192.168.16.254**
- Password: **root**

1. Launch the Internet Explorer.
2. Key in "http://" + "IP Address" of the 4 10/100/1000T + 1 Mini-GBIC Web Managed Switch, and then press "**Enter**".
3. Login screen will appear right after.

4. Key in the default password as “root”.
5. Click , and then configuration is ready to be set up.



Main Interface

System Configuration

Displays system parameters information listed as below, and the other parameters of system can be configured as well.

- **MAC Address:** Displays the unique hardware address assigned by manufacturer (default).
- **S/W Version:** Displays the Software Version of Kernel.
- **H/W Version:** Displays the Hardware Version of the switch.
- **Active IP Address:** Displays the current IP Address.
- **Active Subnet Mask:** Displays the current IP Subnet Mask.
- **Active Gateway:** Displays the current Gateway.
- **DHCP Server:** Displays the DHCP Server IP Address when DHCP check box is enabled.
- **Lease Time Left:** Displays DHCP lease time. After 50% of the lease time

has passed, the client/switch will attempt to renew the lease with the original DHCP server that it obtained the lease from using a DHCPREQUEST message. Any time the client/switch boots and the lease is 50% or more passed, the client/switch will attempt to renew the lease. At 87.5% of the lease completion, the client/switch will attempt to contact any DHCP server for a new lease.

System Configuration

MAC Address	00-ff-38-ff-f2-e1
SW Version	v1.05
HW Version	1.0
Active IP Address	192.168.16.1
Active Subnet Mask	255.255.255.0
Active Gateway	192.168.16.254
DHCP Server	0.0.0.0
Lease Time Left	0 secs

DHCP Enabled	<input type="checkbox"/>
Fallback IP Address	<input type="text" value="192.168.16.1"/>
Fallback Subnet Mask	<input type="text" value="255.255.255.0"/>
Fallback Gateway	<input type="text" value="192.168.16.254"/>
Management VLAN (1~4095)	<input type="text" value="1"/>
Name	<input type="text" value="root"/>
Password	<input type="password" value="••••"/>
Inactivity Timeout (10~10000secs, 0secs means login forever)	<input type="text" value="300"/>

Apply

Refresh

System Configuration Interface

- **DHCP Enable:** Tick the check box to enable DHCP Client Function.
- **Fallback IP Address:** Assign the fallback IP address for DHCP IP assigning

failure (The default IP is 192.168.16.1).

- **Fallback Subnet Mask:** Assign the switch IP Subnet Mask.
- **Fallback Gateway:** Assign the switch Gateway (The default value is 192.168.16.254).
- **TFTP Server Enabled:** Tick this check box to enable the TFTP server function.
- **Management VLAN (1 ~ 4095):** Assign a number of VLAN group between 1 and 4095. It is used for Remote Management Security; in fact, it gives the port permission to access the switch only when the port's VLAN group ID is equal to the Management VLAN ID.
- **Name:** Assign the name of the switch.
- **Password:** Web GUI login password. The default password is **root**.
- **Inactivity Timeout:** Set the timeout period for security in number between 10 and 10000 seconds.
- And then, click to have the configuration take effect.
- Or, click to reset the configuration before applying.

Port Configuration

Specify the negotiation mode, enable flow control, and set maximum frame size in the range between 1518 and 9600 for each port.

- **Link:** “Down” means “No Link”. Link speed status includes: 1000FDX, 100FDX, 100HDX, 10FDX, and 10 HDX. The system will automatically detect link speed.
- **Mode:** Specify the speed, full-duplex or half-duplex mode of the ports.
- **Flow control:** Set Flow Control Function as “enable” or “disable” in Full Duplex mode.
- **MaxFrame (1522 ~ 9600):** Set the Maximum Frame Size in bytes for frames received on the port.

- Click **Apply** to have the configuration take effect.
- Or, click **Refresh** to reset the configuration before Applying.

Port Configuration

Port	Link	Mode	Flow Control	MaxFrame (1522~9600)
1	Down	Auto Speed	<input checked="" type="checkbox"/>	1522
2	100FDX	Auto Speed	<input checked="" type="checkbox"/>	1522
3	Down	Auto Speed	<input checked="" type="checkbox"/>	1522
4	Down	Auto Speed	<input checked="" type="checkbox"/>	1522
5	Down	1000 Auto	<input checked="" type="checkbox"/>	1522

Apply **Refresh**

Port Configuration interface

Statistics-1 (Overview)

The following information provides the current port statistic information.

Press **Clear** button to clean all counts, and then click **Refresh** to get the new setting information shown as below.

Statistics Overview for all ports

Port	Tx Bytes	Tx Frames	Rx Bytes	Rx Frames	Tx Errors	Rx Errors
1	0	0	0	0	0	0
2	45774	79	817310	5770	0	0
3	0	0	0	0	0	0
4	0	0	0	0	0	0
5	0	0	0	0	0	0

Clear **Refresh**

Statistics Overview interface

Statistics-2 (Detailed)

The following information provides statistics detail information on each port, and the user can simply click the port to view the statistics information.

Press button to clean all counts, and then click to get the new setting information as below.

Port 1		Port 2		Port 3		Port 4		Port 5	
Receive Total					Transmit Total				
Rx Packets		0	Tx Packets		0				0
Rx Octets		0	Tx Octets		0				0
Rx Broadcast and Multicast		0	Tx Broadcast and Multicast		0				0
Rx Error Packets		0	Tx Error Packets		0				0

Statistics Detail interface

VLAN Setting

A Virtual LAN (VLAN) is a logical network grouping that limits the broadcast domain, which would allow users to isolate network traffic, and therefore only the members of the VLAN will receive traffic from the members of the same VLAN. Basically, creating a VLAN from a switch is logically equivalent to reconnecting a group of network devices to another Layer 2 switch. However, all the network devices are still plugged into the same switch physically.

- Assign the VLAN ID in number between 1 and 4095.
- Group the members of VLAN by ticking the check box.
- Click to bring up the configuration interface as below.
- Tick all check boxes by clicking '**add all**' or remove all ticks by clicking '**clear all**'.

- There are 16 VLAN entries per page among 16 pages. To search the specified VLAN, please type in the VLAN ID in the empty field beside the label of 'Quick Search Vlan Entry, Vlan ID:' and then press 'Search'.

802.1Q Vlan Setting

Current Page: 1 Total Page:16

Vlan Entry No	Vlan ID/VID(1~4095)	Port1	Port2	Port3	Port4	Port5	Add All Ports	Clear All Ports
1	VID 1	<input checked="" type="checkbox"/>	<input checked="" type="checkbox"/>	<input checked="" type="checkbox"/>	<input checked="" type="checkbox"/>	<input checked="" type="checkbox"/>	add all	clear all
2	VID	<input type="checkbox"/>	<input type="checkbox"/>	<input type="checkbox"/>	<input type="checkbox"/>	<input type="checkbox"/>	add all	clear all
3	VID	<input type="checkbox"/>	<input type="checkbox"/>	<input type="checkbox"/>	<input type="checkbox"/>	<input type="checkbox"/>	add all	clear all
4	VID	<input type="checkbox"/>	<input type="checkbox"/>	<input type="checkbox"/>	<input type="checkbox"/>	<input type="checkbox"/>	add all	clear all
5	VID	<input type="checkbox"/>	<input type="checkbox"/>	<input type="checkbox"/>	<input type="checkbox"/>	<input type="checkbox"/>	add all	clear all
6	VID	<input type="checkbox"/>	<input type="checkbox"/>	<input type="checkbox"/>	<input type="checkbox"/>	<input type="checkbox"/>	add all	clear all
7	VID	<input type="checkbox"/>	<input type="checkbox"/>	<input type="checkbox"/>	<input type="checkbox"/>	<input type="checkbox"/>	add all	clear all
8	VID	<input type="checkbox"/>	<input type="checkbox"/>	<input type="checkbox"/>	<input type="checkbox"/>	<input type="checkbox"/>	add all	clear all
9	VID	<input type="checkbox"/>	<input type="checkbox"/>	<input type="checkbox"/>	<input type="checkbox"/>	<input type="checkbox"/>	add all	clear all
10	VID	<input type="checkbox"/>	<input type="checkbox"/>	<input type="checkbox"/>	<input type="checkbox"/>	<input type="checkbox"/>	add all	clear all
11	VID	<input type="checkbox"/>	<input type="checkbox"/>	<input type="checkbox"/>	<input type="checkbox"/>	<input type="checkbox"/>	add all	clear all
12	VID	<input type="checkbox"/>	<input type="checkbox"/>	<input type="checkbox"/>	<input type="checkbox"/>	<input type="checkbox"/>	add all	clear all
13	VID	<input type="checkbox"/>	<input type="checkbox"/>	<input type="checkbox"/>	<input type="checkbox"/>	<input type="checkbox"/>	add all	clear all
14	VID	<input type="checkbox"/>	<input type="checkbox"/>	<input type="checkbox"/>	<input type="checkbox"/>	<input type="checkbox"/>	add all	clear all
15	VID	<input type="checkbox"/>	<input type="checkbox"/>	<input type="checkbox"/>	<input type="checkbox"/>	<input type="checkbox"/>	add all	clear all
16	VID	<input type="checkbox"/>	<input type="checkbox"/>	<input type="checkbox"/>	<input type="checkbox"/>	<input type="checkbox"/>	add all	clear all

Quick Search Vlan Entry, Vlan ID: Search

Vlan Port Setting

Apply Refresh FirstPage PrePage NextPage EndPage

VLAN Setting interface

VLAN Port Setting

Click **VLAN Port Setting** to bring up the configuration interface for adjusting the VID Setting.

- PVID:** Enter the Port VLAN ID.
- Awareness:** Enable the awareness so that ports will strip the VLAN tag from received frames and insert the tag (contains PVID) into transmitted frames.

Disable the awareness so that ports will not strip the tag from received frames or insert the tag in transmitted frames.

- **Frame Type:** Set the outgoing frame.
 - **Tag:** Outgoing frames with VLAN-Tagged.
 - **All:** All type of frames.
- Click **Apply** to have the configuration take effect.
- Or, click **Refresh** to refresh the configuration to view the newest state.

Vlan Port Setting

Port	PVID(1~4095)	Awareness	Frame Type
1	1	Disable	All
2	1	Disable	All
3	1	Disable	All
4	1	Disable	All
5	1	Disable	All

PVID can be set to 'none' used for trunk links. You can leave this value to none for setting PVID to none.

Apply **Refresh**

VLAN Port Setting interface

Port Trunk

Port trunk allows multiple links to be bundled together and act as a single physical link for increased throughput. It provides load balancing, and redundancy of links in a switched inter-network. Actually, the link does not have an inherent total bandwidth equal to the sum of its component physical links. Traffic in a trunk is distributed across an individual link within the trunk in a deterministic method that called a hash algorithm. Traffic pattern on the network

should be considered carefully before applying it. When a proper hash algorithm is used, traffic is kind of randomly decided to be transmitted across either link within the trunk and load balancing will be seen.

- Select the group members. Normal means the port is not the trunk member.
- Click **Apply** to have the configuration take effect.
- Or, click **Refresh** to refresh the configuration to view the newest state.

Aggregation/Trunking Configuration

Group\Port	1	2	3	4	5
Normal	<input checked="" type="radio"/>	<input checked="" type="radio"/>	<input checked="" type="radio"/>	<input checked="" type="radio"/>	<input checked="" type="radio"/>
Group 1	<input type="radio"/>	<input type="radio"/>	<input type="radio"/>	<input type="radio"/>	<input type="radio"/>
Group 2	<input type="radio"/>	<input type="radio"/>	<input type="radio"/>	<input type="radio"/>	<input type="radio"/>

Apply **Refresh**

Port Trunk interface

LACP Setting

The Link Aggregation Control Protocol (LACP) is a computer networking term and is part of IEEE specification 802.3ad that allows bundling several physical ports together to form a single logical channel. LACP allows a network switch to negotiate an automatic bundle by sending LACP packets to the peer. LACP is a protocol implementation in OSI layer 2 which controls through which physical links the traffic will be routed.

- **Protocol Enable:** Tick the check box to enable LACP protocol of the port.
- **Key Value (auto | 1 - 255):** The LACP key determines which ports potentially can be aggregated together.

- Click **Apply** to have the configuration take effect.
- Or, click **Refresh** to refresh the configuration to view the newest state.

LACP Port Configuration

Port	Protocol Enabled	Key Value(auto (1-255))
1	<input type="checkbox"/>	auto
2	<input type="checkbox"/>	auto
3	<input type="checkbox"/>	auto
4	<input type="checkbox"/>	auto
5	<input type="checkbox"/>	auto

Apply **Refresh**

LACP Setting interface

LACP Status

When the LACP aggregator has been set up, the LACP status information will display as below.

LACP Aggregation Overview

Group/Port	1	2	3	4	5
Normal					

Legend

	Down	Port link down
	Blocked	Port Blocked by RSTP. Number is Partner port number if other switch has LACP enabled
	Learning	Port Learning by RSTP
	Forwarding	Port link up and forwarding frames
	Forwarding	Port link up and forwarding by RSTP. Number is Partner port number if other switch has LACP enabled

LACP Port Status

Port	Protocol Active	Partner Port Number	Operational Port Key
1	no		
2	no		
3	no		
4	no		
5	no		

Refresh

LACP Status interface

Spanning Tree

The Rapid Spanning Tree Protocol (RSTP) is an evolution of the Spanning Tree Protocol and provides for faster spanning tree convergence after a topology change. The system also supports STP and the system will automatically detect the connected device that is running STP or RSTP protocol.

RSTP System Configuration

- System Priority:** A value used to identify the root bridge. The bridge with the lowest value has the highest priority and is selected as the root. If the value has being changed, user has to reboot the switch. The value must be multiple of 4096 according to the protocol standard rule.

- **Hello Time (1-10):** The scale of 1 ~ 10 sec will be set as a period of time that how often the switch broadcasts hello messages to other switches.
- **Max Age (6-40):** The number of seconds (from 6 ~ 40) which determines the amount of time that protocol information received on a port is stored by the switch.
- **Forward Delay Time (4-30):** The number of seconds (from 4 ~ 30) which determines how long each of the listening and learning states will last before the port begins forwarding.
- **Force version:** Select the RSTP default protocol. 'Normal' means RSTP protocol. 'Compatible' means it's compatible with STP protocol.

RSTP System Configuration

System Priority	32768 ▾
Hello Time (1~10)	2
Max Age (6~40)	20
Forward Delay (4~30)	15
Force version	Normal ▾

RSTP Port Configuration

Port	Protocol Enabled	Edge	Path Cost(auto 1-20000000)
Aggregations	<input type="checkbox"/>		
1	<input type="checkbox"/>	<input checked="" type="checkbox"/>	auto
2	<input type="checkbox"/>	<input checked="" type="checkbox"/>	auto
3	<input type="checkbox"/>	<input checked="" type="checkbox"/>	auto
4	<input type="checkbox"/>	<input checked="" type="checkbox"/>	auto
5	<input type="checkbox"/>	<input checked="" type="checkbox"/>	auto

RSTP Configuration interface

RSTP Port Configuration

- **Protocol Enable:** Enable or disable the RSTP protocol for the port.
- **Edge:** An edge port is a port connected to a non-switch device. It is kept in a forwarding state and is not part of the STP topology unless BPDUs are seen on the port. To configure the port as an edge port, tick the check box.
- **Path Cost:** The cost of the path to the other bridge from this transmitting bridge at the specified port. Enter a number 1 through 200,000,000
- Click to have the configuration take effect.
- Or, click to refresh the configuration to view the newest state.

Spanning Tree Status

Click to get the newest configuration information. The Rapid Spanning Tree Protocol information will display as below.

RSTP VLAN Bridge Overview

VLAN Id	Bridge Id	Hello Time	Max Age	Fwd Delay	Topology	Root Id
1	32769:00-ff-38-ff-f2-35	2	20	15	Steady	This switch is Root!

RSTP Port Status

Port/Group	Vlan Id	Path Cost	Edge Port	P2p Port	Protocol	Port State
Port 1						Non-STP
Port 2						Non-STP
Port 3						Non-STP
Port 4						Non-STP
Port 5						Non-STP

RSTP Status interface

802.1X Configuration

IEEE 802.1X is an IEEE standard for port-based Network Access Control; it is part of the IEEE 802 (802.1) group of protocols. It provides authentication to devices attached to a LAN port, establishing a point-to-point connection or preventing access from that port if authentication fails. IEEE 802.1X is available on certain network switches, and can be configured to authenticate hosts which are equipped with supplicant software, denying unauthorized access to the network at the data link layer.

- **Mode:** Disable or enable IEEE 802.1x authentication.
- **RADIUS IP:** Set the Radius Server IP address.
- **RADIUS UDP Port:** Set the UDP destination port for authentication requests to the specified Radius Server
- **RADIUS Secret:** Set an encryption key for authenticating usage sessions with the specified radius server. This key must match the encryption key used on the Radius Server
- **Admin State:** Select the state of port.
 - **Force Authorized:** The specified port is required to be held in the authorized state.
 - **Force Unauthorized:** The specified port is required to be held in the unauthorized state.
 - **Auto:** The specified port is set to the authorized or unauthorized state in accordance with the outcome of an authentication exchange between the Supplicant and the authentication server
- **Re-authenticate:** Restart authentication process for the port.
- **Force Reinitialize:** Restart authentication process for the port.
- **Statistics:** Click to view each port statistic.
- **Re-authenticate All:** Restart authentication process for all the port.
- **Force reinitialize All:** Restart authentication process for all the port
- Click to have the configuration take effect.

- Or, click **Refresh** to refresh the configuration to view the newest state.

802.1X Configuration

Mode:

RADIUS IP:

RADIUS UDP Port:

RADIUS Secret:

Port	Admin State	Port State			
1	<input type="text" value="Force Authorized"/>	802.1X Disabled	Re-authenticate	Force Reinitialize	Statistics
2	<input type="text" value="Force Authorized"/>	802.1X Disabled	Re-authenticate	Force Reinitialize	Statistics
3	<input type="text" value="Force Authorized"/>	802.1X Disabled	Re-authenticate	Force Reinitialize	Statistics
4	<input type="text" value="Force Authorized"/>	802.1X Disabled	Re-authenticate	Force Reinitialize	Statistics
5	<input type="text" value="Force Authorized"/>	802.1X Disabled	Re-authenticate	Force Reinitialize	Statistics
			Re-authenticate All	Force Reinitialize All	

802.1X Configuration interface

Parameters Configuration

You can configure this page to enable client re-authentication and how often it occurs.

- **Reauthentication Enable:** Enable the re-authentication mode.
- **Reauthentication Period (1~3600 seconds):** Set the period of time in second between re-authentication attempts.
- **EAP Timeout (1~255 seconds):** Set the period of time the switch waits for a supplicant response to an EAP request.
- Click **Apply** to have the configuration take effect.

- Or, click **Refresh** to refresh the configuration to view the newest state.

802.1X Parameters

Reauthentication Enabled	<input type="checkbox"/> Enabled
Reauthentication Period [1-3600 seconds]	<input type="text" value="3600"/>
EAP timeout [1 - 255 seconds]	<input type="text" value="30"/>

QoS Setting

Configure QoS mode, port priority, TOS and COS priority setting.

- **Mode:** Specify the QoS mode—port, DSCP, or vlantag.
- **Port Priority:** Select the priority level—low, normal, medium, or high.
- Click **Apply** to have the configuration take effect.
- Or, click **Refresh** to refresh the configuration to view the newest state.

QoS Configuration

Port	Mode	Port Priority
1	port	high
2	port	high
3	port	high
4	port	high
5	port	high

DSCP Mapping

Vlan tag Mapping

Apply

Refresh

QoS Configuration interface

- Click **DSCP Mapping** to enter DSCP priority configuration interface.
 - **DSCP [0- 63]:** The system provides 0 ~ 63 TOS priority level. When the IP packet is received, the system will check the DSCP level value in the IP packet. For example, port 1 is set as DSCP mode and DSCP level 25 is set as high. When the packet is received via port 1, the system will check the DSCP value of the received IP packet. If the DSCP value of the received IP packet is 25 (priority = high), and then the packet priority will have the highest priority.
 - **Priority:** Select the priority level—high, medium, low, or normal
- Click **Apply** to have the configuration take effect.
- Or, click **Refresh** to refresh the configuration to view the newest state.

QoS DSCP Mapping

DSCP [0-63]	Priority
25	high
24	medium
53	normal
60	low
	high
	high
	high
All others	high

Apply Refresh

QoS DSCP Mapping interface

- After having set mode as 'vlan-tag', click **VLAN tag Mapping** to enter VLAN tag priority configuration interface.
- Set the VLAN tag priority level from 0 ~ 7 for each port.
- Click **Apply** to have the configuration take effect.
- Press **Refresh** to refresh the configuration to view the newest state.

QoS Vlan Tag Priority Mapping

Port	VlanTag=0	VlanTag=1	VlanTag=2	VlanTag=3	VlanTag=4	VlanTag=5	VlanTag=6	VlanTag=7
1	low	low	normal	normal	medium	medium	high	high
2	low	low	normal	normal	medium	medium	high	high
3	low	low	normal	normal	medium	medium	high	high
4	low	low	normal	normal	medium	medium	high	high
5	low	low	normal	normal	medium	medium	high	high

Apply Refresh

QoS VLAN Tag Priority Mapping interface

System Restart

Reboot the switch in software reset.

Click to restart the system.

Warm Restart

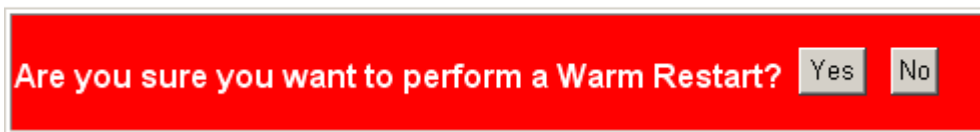

System Restart interface

Factory Default

Reset the switch to default configuration.

Click to reset all the configurations to factory default value.

Factory Default



Factory Default interface

Firmware Upload

The system provides the Web GUI firmware upgrade function which allows users to upgrade the switch firmware.

- Click to locate the firmware.

- And then, press **Upload** to update the firmware.

Software Upload

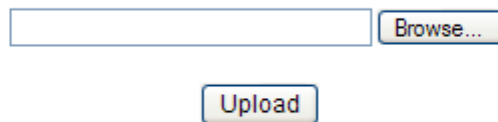

The image shows a web interface for software upload. It consists of a horizontal text input field on the left and a 'Browse...' button on the right. Below these elements is a single 'Upload' button.

Warning: Upload Progress cannot be interrupted. You should not open other webpages when uploading. This operation may cause system to crash very easily. When you have to do this, we strongly suggest you to reboot system before upgrade.

Software Upload interface

Configuration Upload/Download

The system provides the Web GUI configuration file transfer function which would allow user to backup and restore the switch configuration.

- Click **Browse** to locate the file.
- And then, press **Upload** to upload the file.

Configuration Upload

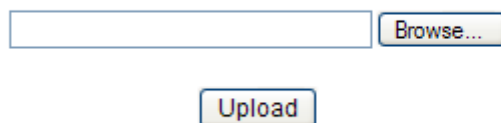

The image shows a web interface for configuration upload. It consists of a horizontal text input field on the left and a 'Browse...' button on the right. Below these elements is a single 'Upload' button.

Configuration Download

Configuration Upload interface

- And then, press **Yes** to update the loaded file.

Configuration successfully loaded

Do you want to update Configuration?

- For restoring the configuration, press to restore the file.

Configuration Download

Configuration Download interface

Troubleshooting

This section is intended to help users to solve the most common problems on the 4 10/100/1000T + 1 Mini-GBIC Web Managed Switch.

Incorrect connections

The switch port can auto detect straight or crossover cable when the switch link with other Ethernet device. For the RJ-45 connector should use correct UTP or STP cable, 10/100Mbps port use 2 pairs twisted cable and Gigabit 1000T port use 4 pairs twisted cable. If the RJ-45 connector is not correctly pinned on right position then the link will fail. For fiber connection, please notice that fiber cable mode and fiber module should match.

■ Faulty or loose cables

Look for loose or obviously faulty connections. If they appear to be OK, make sure the connections are snug. If that does not correct the problem, try a different cable.

■ Non-standard cables

Non-standard and miss-wired cables may cause numerous network collisions and other network problem, and can seriously impair network performance. A category-5 cable tester is a recommended tool for every 100Base-T network installation.

RJ-45 ports: Use unshielded twisted-pair (UTP) or shielded twisted-pair (STP) cable for RJ-45 connections: 100 Ω Category 3, 4 or 5 cable for 10Mbps

connections or 100Ω Category 5 cable for 100Mbps connections. Also be sure that the length of any twisted-pair connection does not exceed 100 meters (328 feet). Gigabit port should use cat-5e or above cable for 1000Mbps connections. The length does not exceed 100 meters.

■ Improper Network Topologies

It is important to make sure that users have a valid network topology. Common topology faults include excessive cable length and too many repeaters (hubs) between end nodes. In addition, users should make sure that network topology contains no data path loops. Between any two ends nodes, there should be only one active cabling path at any time. Data path loops will cause broadcast storms that will severely impact network performance.

Diagnosing LED Indicators

To assist in identifying problems, the switch can be easily monitored through panel indicators which describe common problems the user may encounter and where the user can find possible solutions.

If the power indicator does not turn on when the power cord is plugged in, the user may have a problem with power outlet, or power cord. However, if the switch powers off after running for a while check for loose power connections, power losses or surges at power outlet. If the problem still cannot be resolved, contact the local dealer for assistance.

Technical Specification

This section provides the specifications of 4 10/100/1000T + 1 Mini-GBIC Web Managed Switch.

<p>Standard</p>	<p>IEEE 802.3 10BASE-T Ethernet IEEE 802.3u 100BASE-TX Fast Ethernet IEEE 802.3ab 1000Base-T IEEE 802.3z Gigabit Fiber IEEE 802.3x Flow Control and Back-pressure IEEE 802.1d Spanning Tree IEEE 802.1w Rapid Spanning Tree IEEE 802.3ad Port trunk with LACP IEEE 802.1p Class of Service IEEE 802.1x user authentication IEEE802.1Q VLAN Tagging</p>
<p>Protocol</p>	<p>CSMA/CD</p>
<p>Technology</p>	<p>Store-and-Forward switching architecture</p>
<p>Transfer Rate</p>	<p>14,880pps for 10Mbps 148,800pps for 100Mbps 1,488,000pps for 1000Mbps</p>
<p>LED Indicators</p>	<p>Per RJ-45 port: 100/1000, Link/Activity, Full duplex/ Collision Per MINI GBIC: Link/Activity Per unit: Power</p>

Network Cable	<p>10BASE-T: 2-pair UTP/STP Cat. 3, 4, 5 cable EIA/TIA-568 100-ohm (100m)</p> <p>100BASE-TX: 2-pair UTP/STP CAT. 5 cable EIA/TIA-568 100-ohm (100m)</p> <p>Gigabit Copper: 4 pair UTP/STP CAT. 5e cable EIA/TIA 568 100-ohm (100M)</p>
Connector	<p>Gigabit copper: 4 x RJ-45 with Auto-MDIX</p> <p>MINI GBIC: 1 x MINI GBIC socket (3.3v)</p>
Back-plane	10Gbps
MAC address	8K
Memory Buffer	112Kbytes
Jumbo packet	Supports 8Kbytes Jumbo Frame
Dimensions	165 x 100 x 32.5 mm (W x D x H)
Power Supply	External power DC 12V/0.8A
Power Consumption (DC)	5.1 Watt (maximum)
Operating Temperature	0°C to 45°C (32°F to 113°F)

Operating Humidity	10% to 90% (Non-condensing)
EMI	FCC Class A, CE
Safety	UL, cUL

Appendix

10 /100BASE-TX Pin outs

With 10/100BASE-TX cable, pins 1 and 2 are used for transmitting data, and pins 3 and 6 for receiving data.

■ RJ-45 Pin Assignments

Pin Number	Assignment
1	Tx+
2	Tx-
3	Rx+
6	Rx-

[NOTE] “+” and “-” signs represent the polarity of the wires that make up each wire pair.

The table below shows the 10 / 100BASE-TX MDI and MDI-X port pin outs.

Pin MDI-X	Signal Name	MDI Signal Name
1	Receive Data plus (RD+)	Transmit Data plus (TD+)
2	Receive Data minus (RD-)	Transmit Data minus (TD-)
3	Transmit Data plus (TD+)	Receive Data plus (RD+)
6	Transmit Data minus (TD-)	Receive Data minus (RD-)

10/100Base-TX Cable Schematic

The following two figures show the 10/100Base-TX cable schematic.

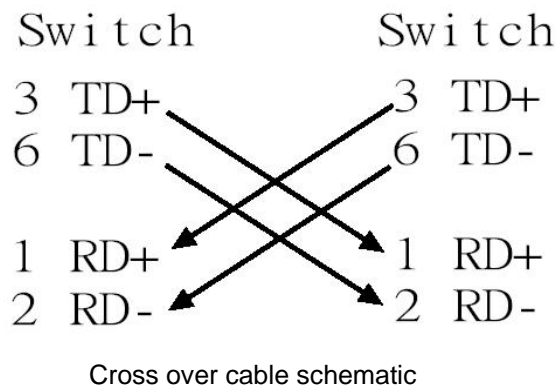
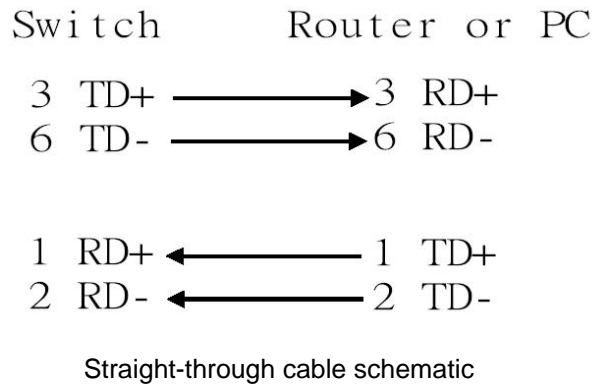

10/100/1000Base-TX Pin outs

The following figure shows the 10/100/1000 Ethernet RJ-45 pin outs.

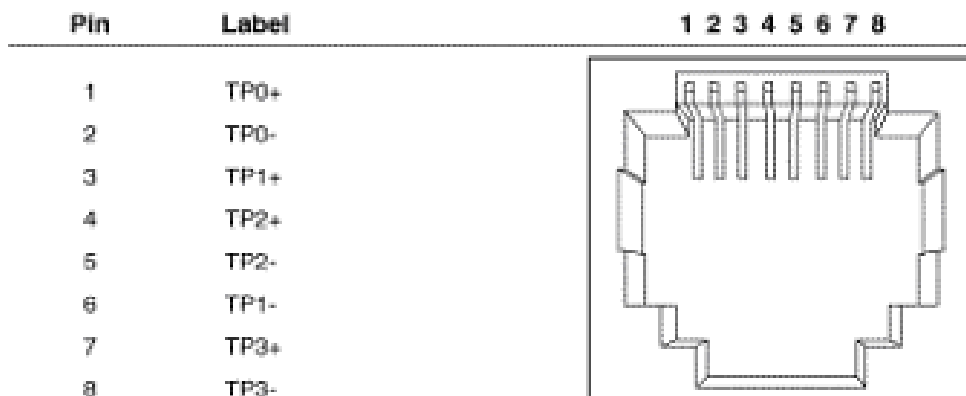

10/100/1000Base-TX Cable Schematic

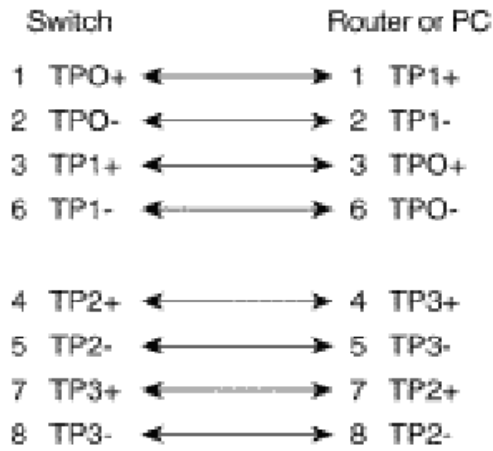

Straight through cables schematic

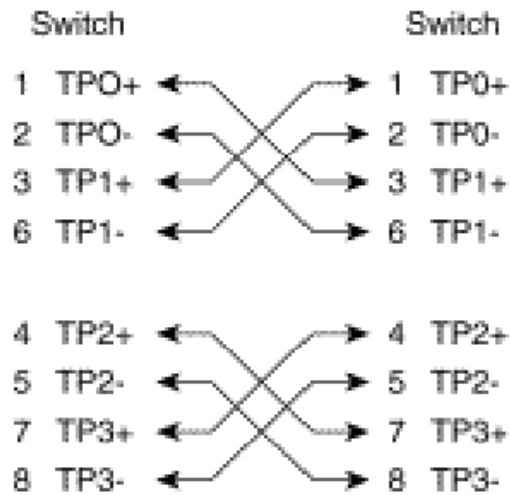

Cross over cables schematic